

ReGen™ Hydromassage Side Entry, Walk-In Bath System

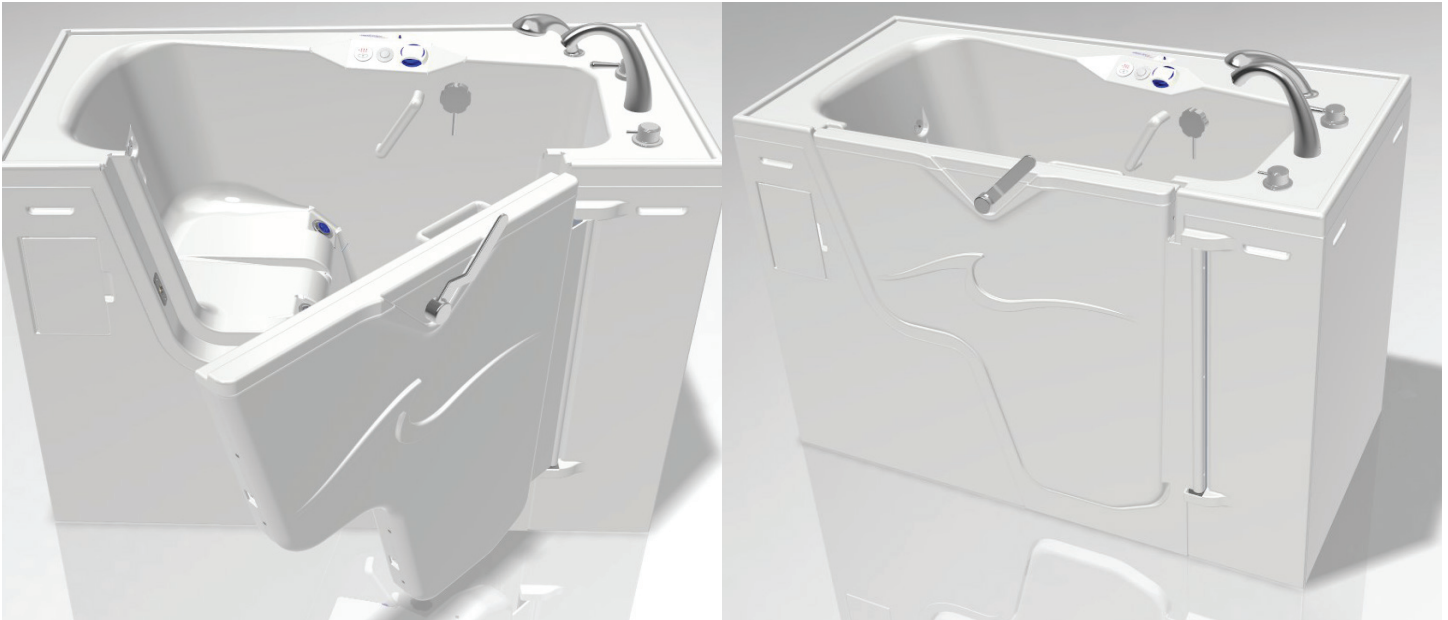

ReGen™ Side Entry Walk-In Bathing System Features:

- Standard bathtub footprint: 59.6" L × 30.1" W × 40.5" H
- Low step threshold for easy access
- Easy access maintenance panels
- Quick drain feature
- Medical grade gel coated fiberglass for long lasting lifetime warranty
- Bacteria resistant, easy to clean
- Limited lifetime warranty on all other parts
- ADA compliant (Seat at 17" minimum height)
- Anti-slip foot zones
- Easy to operate locking/unlocking door handle
- Wide door designed to swing over 'most' toilet seats
- Leveling legs lift compatible / adjust height of tub to accommodate lifts if needed. (note, changes 4" threshold)
- 16 Hydro massaging AIR X™ jets: 8 high air flow, 6 aerated and 2 low velocity/high waterflow

Optional Add-On Features:

Remedy™ UV Germicidal Water Purification System

Purifies water as you bathe.
 Reduces bacteria levels, and self infections.

Seat and back warmer for maximum comfort.

In-line water heater.

Helps maintain water temperature throughout a 20 minute bath.

Thermostatic Mixing Valve.

Sets maximum/minimum temperatures, ensuring no scalding of skin.

Integrated disinfectant/cleaning delivery system.

Incorporates the 2 step CDC recommended process of disinfecting: Turbo Clean pre-cleaner and Cidal II quaternary disinfectant.

ReGen™ Hydromassage Side Entry, Walk-In Bath System

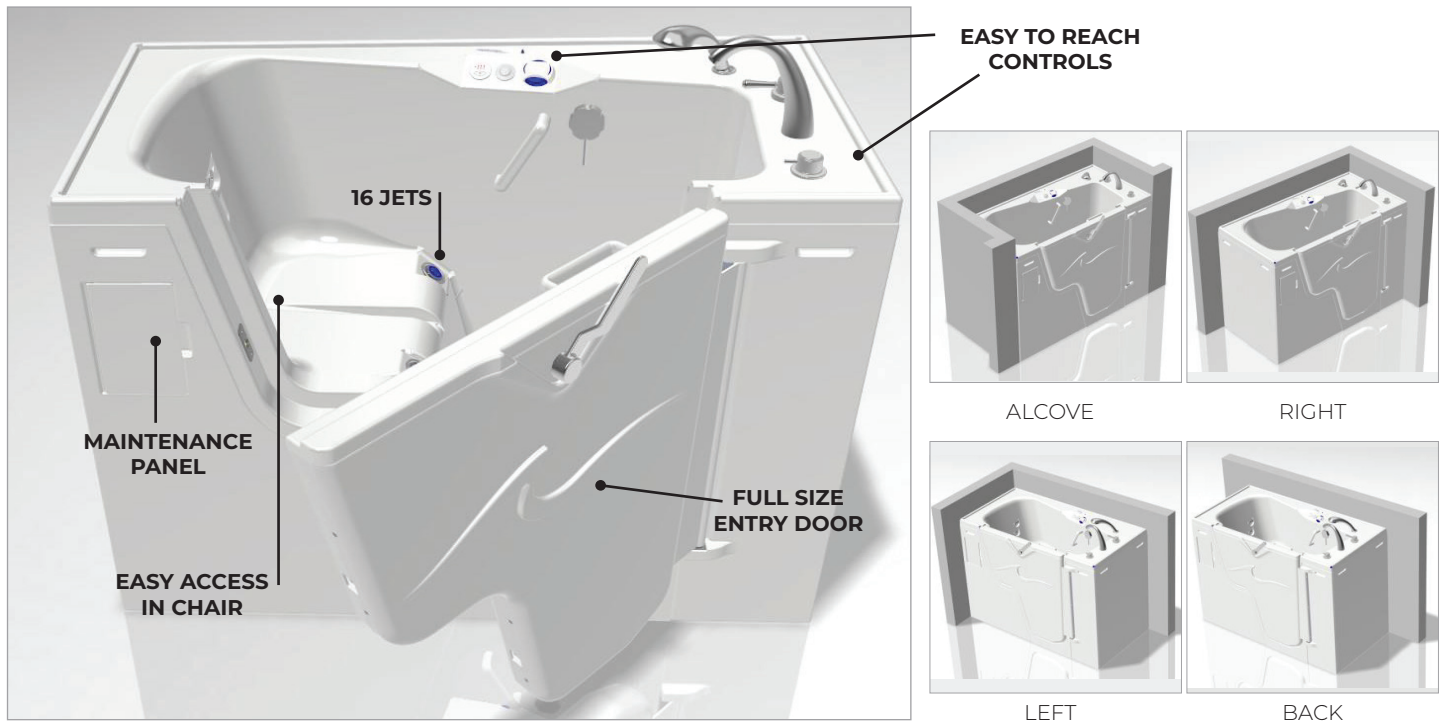

Dimensions	L: 59.6 in. (190.0 cm)	W: 30.1 in. (88.6 cm)	H: 40.5 in. (117.1 cm) To Deck
Total Shipping Weight	600 lbs. (272 kg)		
Water Supply	Requires (2) 0.75 in NPT wall mounted faucets. Minimum of 30 PSI (2.1 bar) for hot and cold required.		
Water Connection	Provided with (2) 24 in. (152.4 cm) Braided Stainless Steel Hoses with 0.75 in NPT ends. Extension hoses available upon request.		
Waste	1-1/2 in PVC schedule 40 pipe. Outside diameter 1.9 in. (6.1 cm)		
Electrical	Without In-Line Water Heater: 1 Dedicated 115 VAC 15A GFCI circuit breaker. With In-Line Water Heater: 2 Dedicated 115 VAC 15A GFCI circuit breakers.		
Tub Fill	ASSE 1070 or 1016 certified thermostatic mixing valve.		
Shower	Handheld with 84 in. (213.4 cm) ASME A112.18.1 hose.		
Tub Entry	38.9" Outswing door.		
Gasket	D-shaped, ASTM D2000, EPDM extrusion.		
Whirlpool Pump Motor	1.5 HP, 110-120VAC, 60 Hz, 13 A, 125 GPM max flowrate.		
Whirlpool Jets	(6) Aerated hydromassage jets, (8) high airflow hydromassage jets, (2) low velocity high waterflow hydromassage jets.		
In-Line Water Heater	Maintains water temperature up to 105° F.		
Surface Heater	Seat and back surface heaters with safety timer and thermostat to prevent scalding.		
Germicidal UV Lamps	(2) 20W, 425 mA lamps producing a UV output of 6.4W each. 10,000 hr. rated effective life.		
Whirlpool Water Requirement	65 gal. minimum required to run whirlpool jets without bather.		